

# Identifying Woven Textiles 1750–1950

DATS in partnership with the V&A



## Identifying Woven Textiles 1750–1950

This information pack has been produced to accompany two one-day workshops taught by Katy Wigley (Director, School of Textiles) and Mary Schoeser (Hon. V&A Senior Research Fellow), held at the V&A Clothworkers' Centre on 19 April and 17 May 2018.

The workshops are produced in collaboration between DATS and the V&A.

The purpose of the workshops is to enable participants to improve the documentation and interpretation of collections and make them accessible to the widest audience. Participants will have the chance to study objects at first hand to help increase their confidence in identifying woven textile materials and techniques. This information pack is intended as a means of sharing the knowledge communicated in the workshops with colleagues and the wider public and is also intended as a stand-alone guide for basic weave identification.

Other workshops / information packs in the series:

Identifying Textile Types and Weaves

Identifying Printed Textiles in Dress 1740–1890

Identifying Handmade and Machine Lace

Identifying Fibres and Fabrics

Identifying Handmade Lace

Front Cover: Lamy et Giraud, Brocaded silk cannetille (detail), 1878. This Lyonnais firm won a silver gilt medal at the Paris Exposition Universelle with a silk of this design, probably by Eugene Prella, their chief designer. Its impact partly derives from the textures within the many-coloured brocaded areas and the markedly twilled cannetille ground. **Courtesy Francesca Galloway.**

# Identifying Woven Textiles 1750–1950

<b>Table of Contents</b>		<b>Page</b>
<b>1.</b>	<b>Introduction</b>	<b>4</b>
<b>2.</b>	<b>Tips for Dating</b>	<b>4</b>
<b>3.</b>	<b>Fibres and Yarn</b>	<b>5</b>
<b>4.</b>	<b>Looms</b>	<b>17</b>
<b>5.</b>	<b>Finishing</b>	<b>22</b>
<b>6.</b>	<b>Identifying Weaves</b>	<b>25</b>
<b>7.</b>	<b>Further Reading</b>	<b>40</b>
<b>8.</b>	<b>Places to Visit</b>	<b>42</b>
<b>9.</b>	<b>Picture Credits</b>	<b>44</b>

## 1. Introduction

The focus of this guide falls on European and North American woven textiles dating from 1750–1950, although many facets of the woven cloths discussed are relevant to the study of non-European textiles as well as those made at a date prior to 1750. As a rough guide, the period we are looking at divides into two halves: the first characterised by the use of hand spun yarns and natural dyes, and the second, starting around 1850, on machine spun yarn and mineral and synthetic dyes.

Our approach has been to begin with the fundamental characteristics that can be observed with the naked eye or a hand-held magnifier. In addition, we have also included a basic guide to other factors that will help to date both garments and cloths.

## 2. Tips for Dating

Does your item have a fibre content label?

If your item has country of origin label then it will have been sold (in the UK) from 1887 onwards.

When you look at the cloth can you see an uneven surface? If it is made from cotton this could mean that it is made from a hand spun yarn and would most likely pre-date 1820.

If the fibres in your cloth are all linen, particularly finely spun flax, then it is most likely to pre-date World War I.

You can tell the difference between hand spun linen and machine spun linen – which is very uniform and post-dates 1850.

Is the textile pictorial or contain a repeating motif? This can help to date a piece because such textiles are more commonly illustrated in published or online sources.

How formal is it? How abstract? Don't be fooled because from the 1860s to 1880s there are some strong black and white geometric patterns that look like they were designed in the 1930s.

Has the fabric faded? Check inside any seams or compare the colours from the front to the back. Colours that have become lighter but retain the original shade are most likely to be natural dyes, which were only gradually replaced as the nineteenth-century progressed. Indigo was the last to be replaced in *circa* 1890 with its synthetic counter-part.

Colours that have changed in shade (for example, from lilac to bronze) are most likely to be synthetic dyes that post-date 1856 and are not in common use until *circa* 1871.

## 3. Fibres and Yarn

### Natural Fibres

These fibres can be divided into two main categories: animal and plant. The principle natural fibres that would be encountered between 1750 and 1950 are silk and wool (proteins) and cotton and flax (plants). The former are the most receptive to natural dyes, preferring acidic environments, while the latter – especially flax – are more difficult to dye and only readily attract alkaline colourants such as indigo.

Plant fibres are the largest group of these natural fibres, comprising mainly of cellulose and including: cotton; bast fibres such as flax, hemp and nettles including ramie; grasses, palm vines and leaves; rushes and reeds such as esparto and papyrus; and pulped leaves such as yucca and sisal.

Protein fibres are complex organic compounds consisting of one or more chains of amino acids linked by peptide bonds (–NH–CO–) and manufactured by cells. One, keratin, is an insoluble fibrous protein and is the major constituent of silk and all mammalian coats whether called hair, wool or fur. They are destroyed by alkalis.

### Identifying Natural Fibres – Animal

#### Silk

Scholars agree that northern China was the origin of early silk culture and is the original home of the silkworm, the larvae of the domestic silk moth, *Bombyx mori*. Although already ancient, it is recorded that the Empress His-Ling-Shi first developed *sericulture* as a managed production in around 2500 BCE. The earliest known silk threads in the West were found among fabrics retrieved from three Hallstatt graves (600–500 BCE) in Hohmichele, Hochdorf and the Baden-Württemberg region, all in modern-day southwestern Germany.

A silkworm can spin approximately one mile of filament with which it will build its cocoon. The farmed silk cocoon is soaked in very hot water to capture the end of the outermost strand so the fibre can be unrolled, or reeled, after which it is *thrown*, or twisted with other silk strands, typically eight or more, to form a yarn that is more readily managed. This cultured silk is off-white and has a fine smooth texture.

The terms **schappe** and **bourette** refer to two grades of silk yarn that are made from waste silk and damaged cocoons; schappe is spun from partially de-gummed waste silk strands, while bourette is produced from schappe waste, cocoon nubs and other waste and is much 'bumpier' in appearance. Both are now called **silk noil**. Indian **Tussah** and **Muga** are the two most common types of wild silk and made of *staple* silk fibres: the filament is broken due to the mature moth eating its way out of the cocoon as part of its natural life cycle. These silks have a coarser feel due to the silkworm's diet, habitat and creation of shorter filaments. It can vary in colour from pinky-beige to yellow and dark brown.

Silk is a protein fibre and is the only natural filament fibre. *Bombyx mori* can be dyed, painted and printed easily, whereas wild silks were not widely dyed or printed until Thomas Wardle perfected a means of doing so between 1867 and 1878, and such silks tend to have subtle rather than bright colours. Known for its warmth, handle, breathability and superior strength (greater than that of a steel strand of the same diameter), silk has historically been a luxury fibre and used for both interiors and fashion, as well as for cold weather under- and outer-garments. Throughout centuries it has been traded as a commodity and silk buttons were still used as a currency in Britain during the eighteenth-century. Fabrics made from silk include damask, taffeta, satin, and velvet.

### Identifying silk

Farmed silk is a solid fibre and, although smooth, has an irregular triangular surface when viewed through a microscope. These triangulations aid light reflection and give woven fabrics lustre. Silk yarn will be spun using several threads, either loosely or tightly and can be mixed-spun with other fibres. The broken filaments of the inner parts of the cocoon, the *silk noils* or *silk waste*, are also used and spun like any other staple fibre. These yarns – also called *bourette* and *schappe* – will look visually softer and more irregular than the solid silk fibre but still retain its lustre. Wild silk has striations along the length of the fibres and cannot be bleached: it is therefore not manufactured in light colours. It has a duller lustre and pronounced texture. Many silks during the nineteenth century were treated with metallic salts (such as tin) in a process called *weighting*, which produced better drape and absorption. Unfortunately, these types of fabrics age quickly and tend to shatter.

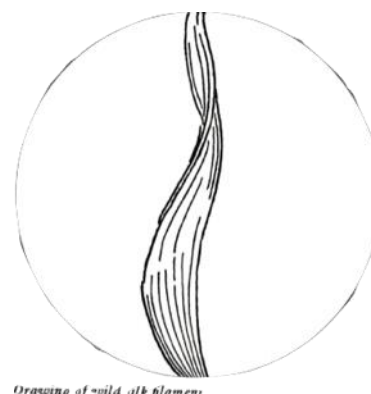

Silk is easily harmed by sunlight and curtains will quickly fade and split where exposed to direct light. Silk has a moderate resistance to wrinkling, swells only slightly when wet and does not shrink. It will water-spot quite easily and can be damaged or yellowed with washing detergents. Silk can be attacked by insects and will self-extinguish when removed from a flame.

### Wool

The earliest woven wool fabrics found in Europe are from a grave in Bosnia and Herzegovina and are believed to date from 1880 to 1550 BCE. The term *wool* covers fibres from such animals as sheep, Angora and Cashmere goats, camel, alpaca and llama. The fleece of early, more primitive sheep had a long hairy outer coat (*kemp*) whereas modern breed sheep have mainly a softer undercoat, and different breeds produce wool with different characteristics.

Wool's thermal qualities have been invaluable in the cold and damp north European climates and finer quality woven wool fabrics were used as a trading currency. The previously flourishing woollen trade started to decline in some of the smaller towns across England from the mid-eighteenth century: especially those in Essex, Suffolk and Norfolk, although excluding Norwich which continued to fair well until the middle of the nineteenth century. At this same time key places, like the West Riding in Yorkshire, grew in importance and by 1850 the West Riding contained 95 per cent of the country's woollen weaving looms.

Wool is a natural bi-component fibre and has an irregular three-way natural crimp. The fibre naturally bends back and forth and twists creating the important properties of cohesiveness, elasticity and loft. Undamaged fibres bounce back immediately and returned to their natural crimped position. It is water repellent whilst remaining breathable and when tightly woven was often used for coats and outerwear. **Worsted** wools are made from the carded and combed long staples of wool fibres that have been tightly woven creating a smooth, firm and slightly reflective surface. These types of wools were often used for fine or expensive cloths and were popular for printing.

Due to its flexibility wool has been used for a wide variety of items including underwear, dresses, shawls, waistcoats, stockings, upholstery and curtains. It has good drape, lustre and texture and wears well. It can be finely spun as sheer wool **voile**, for printed wool **challis**, as medium weight cloths for flannels and gabardine, and for heavier weight tweeds. Wool can also be felted.

### Identifying wool

Wool fibre is a cross-linked protein called keratin. It can be compared to a coiled spring and under a microscope looks like scales wrapped around a central shaft. In fine wools the scales tightly cover themselves and the shaft, while in coarser wool the scales resemble roof tiles. It resists abrasion well and due to its ability to elongate under pressure will pull back to the original fibre positions. Water, steam and humidity encourage wool to bounce and lose wrinkles. Wool does not soil easily but is susceptible to damage when wet. Wool can be blended with many different yarns and woven in almost all weave structures and is attacked easily by moth and insects. Wool burns very slowly and is self-extinguishing to the point where it is considered almost flame-resistant.

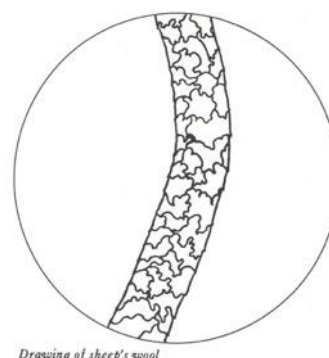

## Identifying Natural fibres – Vegetable

### Cotton

Cotton spinning and weaving is closely associated with India, where cotton seeds dating to 5,000 BCE have been found. Domesticated in Peru and Ecuador some 1,000 years later, by the eighteenth-century principal plantations were located in the Caribbean and southern American colonies, where it became a significant crop in the nineteenth century. It requires a long growing season of a hot climate, rainfall and irrigation for the cellulose to form. The mechanisation of the cotton spinning process began in the 1770s in Britain but machine weaving of cotton in Britain was not common until about 1820. If your fabric sample has irregularly-spun cotton yarn then it most likely pre-dates 1820. Manchester grew to be the most productive spinning centre of the world by the second/third quarter of the nineteenth century and acquired the nickname 'Cottonopolis'. By 1912 the British cotton industry was at its peak, producing eight billion yards of cloth.

Like all plant fibres, cotton is composed of cellulose. Raw cotton is a single cell fibre and ranges in length from 1.5–5 cm (½ to 2 inches), is creamy white in colour and grows from a single seed. Longer cotton fibres are finer and make a stronger yarn. It is a highly absorbent as a textile, has good handle and conducts both heat and electricity.

The versatility of the fibre meant that it could be used for products within the cosmetics industries, homeware and farming. Woven and printed cotton fabrics were used for fashion and interiors, including dress, trousers, lining, handkerchiefs, nappies, curtains, tablecloths, bed linen and lace making. Cotton fabric drapes well and can range from light, soft, sheer fabrics to sturdy denim: all dependant on the yarn type, processing and weave structure. The fabric was finished in different ways including **chintzing**, brushing and polishing. It has also been used within industry for making cords, packaging and flour sacks. Finely woven cottons could also have been glazed, of which there are many nineteenth century museum samples, where the glaze has long since worn away or been washed off. Cotton fabrics include muslin, calico, gingham, moleskin and velveteen.

### Identifying cotton

Cotton fibres can be altered by different chemical processes and finishing treatments. The *mercerisation* of cotton requires the yarn to be treated with sodium hydroxide, making the fibre swell, increasing absorbency and improving its ability to accept dye. Through a microscope a mature cotton fibre looks like a hollow tube wrapped in layers of bundles of cellulose chains resembling a growth ring. These ribbon-like structures twist with a reverse spiral twisting inside its centre, enabling the fibres to attach to one another. This means that fibres are easier to spin, but can attract dirt more quickly and sometimes need vigorous cleaning.

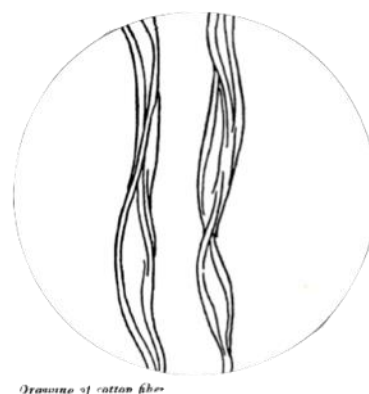

*Diagram of cotton fibre*

Cotton has a high wet strength, dyes extremely well and is cool to the touch. It is a versatile fibre and is often mixed with a weaker fibre to add strength to woven cloths. It can be harmed by acids and does not respond to static. Cotton fibres ignite quickly when lit, burning freely with an afterglow and leaving grey ash.

### Linen

Varieties of bast fibres are found worldwide and remnants of flax and hemp have been found in Stone Age sites located in central Asia, Peru, and Europe, where wild flax dated to 36,000 BCE have been found in modern-day Georgia. It is the use of cultivated flax that marks a society's transition from the opportunistic manipulation of found plant materials to the deliberate planting, harvesting, and processing of a fibre crop, itself identifying of Neolithic cultures. Seeds of cultivated flax dated to *circa* 8000 BCE have been found in Neolithic sites in Syria and in Western Iran, while the earliest woven linen textiles, radiocarbon-dated to 6000 BCE, are also from the Near East, coming from Çatal Hüyük in Anatolia, or present-day Turkey. Later examples have been found in sites as distant as prehistoric lake dwellings in Switzerland and 3,000-year-old Egyptian tombs. Flax yarns and resulting fabrics are called linen, a term that also sometimes is used for fibres from similar bast (or stem-skin) plants, especially hemp. Various nettles including ramie, native to the Far East, are also basts. Because many archeological examples were unearthed prior to the development of today's analytical equipment, ancient cloths identified as linen may be of a bast fibre other than flax.



Finely spun and woven linen shirts circa 1550–1600 were high value items and very fine linen was considered a luxury textile, with Holland and Flanders being the main centres in Europe. As Protestant artisans dispersed during the later seventeenth century, lower quality hand woven linens became the principle economic activity in Scotland during the eighteenth century, although cloths were sent to Flanders for bleaching. At the beginning of the eighteenth-century English linen production was a cottage industry but became part of larger manufacturing units during the 1730s, when printing on **fustian** (linen warp, cotton weft) was legalised. Irish linen was recorded during the twelfth century as being exported across Europe, but rose to its greatest height after 1750, with the importation of seeds from North America, after which it became synonymous with quality. The linen industry was gradually overtaken during the nineteenth century with the rise of cotton. Once the cheapest of fibres, flax production was severely curtailed by agricultural devastation during World War I and the Russian Revolution, becoming costly and thus much less common thereafter.

Linen made from flax fibre has characteristics of body, strength, durability, reduced pilling, beautiful drape and a crisp or soft finish. Often used for high quality bed linens, table linen and upholstery, as well as underwear and linings, it can be made in different weights. It has a high lustre that is the result of very long fibres, typically 30–100 cm (12 to 40 inches) in length. This lustre will increase when the fibres are flattened under pressure during the finishing process. One of the main processes of manufacturing flax is *retting*: loosening of the flax fibres so they can be removed from the stalk. Other processes include *hackling*, or combing to align the fibres. The longer, better quality fibres are called *line* and the shorter flax fibres are called *tow*.

Flax has a strong breaking point and so has been used for a variety of interior, home ware and fashion items. Stronger when wet and impervious to salt water, it dominated the making of maritime ropes and canvases. It is a good conductor of heat and is resistant to alkalis and high temperatures. The fabric can also be finished in different ways, including polishing, calendering and starching. Its strong fibres and slow-burning properties meant that it was also used in different cord and string manufacture as well as for items such as candlewicks. Linen cloths include crash, cambric, butcher linen, buckram and holland.

### Identifying linen

Flax is made from individual spindle-shaped fibre cells that have *joints* on them called nodes and can resemble bamboo when viewed through a microscope. As a bast fibre, which means that it comes from the inner bark or phloem of the stem plant, it is largely cellulose and has a longer polymer than cotton. Linen wrinkles easily, thus holding deliberate pleats well; unintended creases need to be removed with steam and a warm iron. Linen shrinks and has a natural resistance to sunlight. Mildew can be a problem. Flax burns in a similar way to cotton and has a smell of burning grass: fibre length is the best way to identify between the two – linen fibres being longer, finer and glossier.

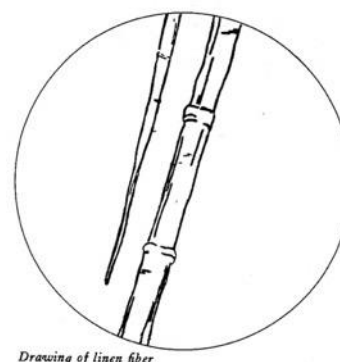

## Man-Made & Synthetic Fibres

Man-made fibres such as viscose rayon and acetate are reconstructed from naturally occurring materials such as trees, cotton and woody plants, all of which contribute a cellulosic base. Synthetic fibres such as polyester, spandex and nylon are created only from synthetic substances.

Both types of fibres are extracted in similar ways and created by the extrusion of the fibre-forming substances in liquid form through fine holes within a spinneret. The liquid is expelled at force and hardened to form solid filaments which are then drawn or stretched and can be twisted together to form yarns of almost any length. These types of yarns are known as *continuous filament yarns* and due to their smooth finish are often used for satins, failles, taffetas, etc.

Generally, fibres such as polyester and acrylic are made by obtaining or creating polymers, which are modified for use as fibres, thermoplastics and paints. If you are looking at a textile that has a mix of natural and synthetic yarns such as a poly-cotton, then it will post-date 1950.

### Identifying man-made fibres

#### Viscose Rayon

British consultant chemists Charles Cross, Edward Bevan and Clayton Beadle discovered viscose (or sodium cellulose xanthate) in 1892. The lustrous fibres suggested possible use within textiles and became known as *artificial silk*. They formed the Viscose Syndicate Ltd in 1894. Made from plant cellulosic fibres (in the form of wood pulp), the patent for viscose rayon was purchased by Courtaulds in 1904 and following a series of technical improvements, they commissioned Wardle & Davenport to make the first viscose rayon stockings in 1912. Commercial production also began in the United States in 1910 and continued to be sold as artificial silk until 1924 when the name *rayon* was adopted.

Initially popular for underwear as well as accessories, in the early days the main markets were in smaller items such as ribbons and braids but also in knitted goods. By 1914 viscose rayon was used in 40 per cent of all stockings. In 1925 Courtaulds launched *fibro*, a technique developed to cut and crimp rayon into filament fibres, creating a textured rayon yarn. Patterned and plain rayon textiles were also produced for curtains and bedding. Rayon fibres were naturally bright and difficult to dye, which tended to limit its use within fashion and interior textiles. At the outbreak of the World War Two, 75 per cent of the total weight of rayon used went into weaving for the war effort.

### Identifying rayon

Under a microscope the yarn will be one continuous filament (unless made from a staple rayon yarn) and is characterised by the lengthwise lines called *striations*. The cross section of the fabric is serrated – which also aids the dyeing process as it increases the fibre’s surface area and will indicate a date approaching 1940. Filament rayon has a bright, smooth and reflective surface that has visual similarities to silk although it is a much weaker fibre and loses about 50 per cent of its strength when wet. Early viscose rayon fabrics included **tweed**, challis, chiffon and transparent velvets. The physical properties remained the same until about 1940 when a high-tenacity rayon was developed making the fabric stronger and less fragile when wet. Rayon has excellent draping qualities, good colourfastness and is cool to the touch. It has a tendency to snag easily and ignites quickly, burns readily and can mildew if not stored correctly.

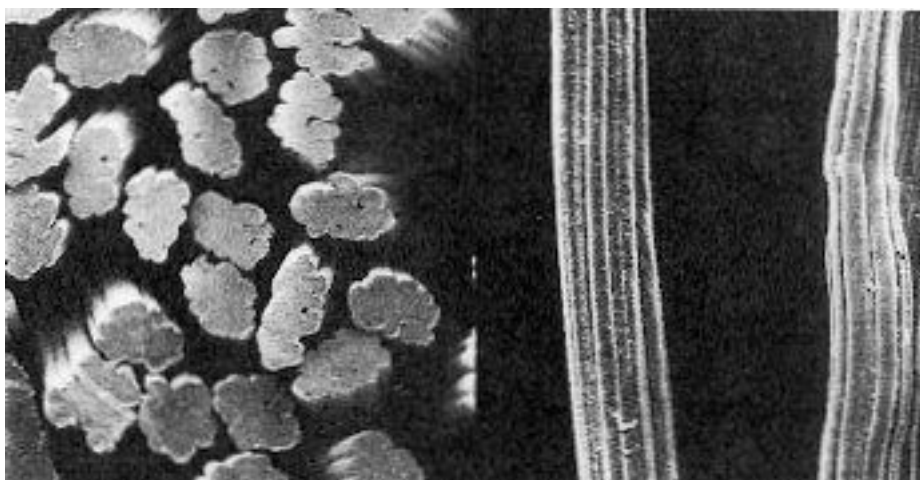

### Acetate

Charles Cross and Edward Bevan also discovered the acetate ‘Celanese’, which needed much development before it became manufactured commercially and was originally developed as a plastic coating for aeroplanes. Developed by Courtaulds as a chemical derivate of cellulose, cellulose acetate, or acetate as it is generally called, went into manufacture in 1927 and sold under the name *Seraceta*. Made from purified wood pulp or cotton linters, it is made as one continuous filament yarn that can also be chopped to create a staple filament yarn. Several stretched acetate yarns were also developed during 1939–45 but failed to maintain a place in the market following their wartime usage. Acetate was promoted as a luxury fibre and became widely used in **satins** and **taffeta**. It had more body and a better draping quality than rayon and became more popular for dress material and garment linings.

### Identifying acetate

Acetate is a weak fibre and has a tendency to break, losing strength when wet. It has a smooth texture and under a microscope will be seen as one continuous filament (unless made from a staple rayon yarn) and is characterised by its flower petal-shaped fibres. Flatter shaped acetate fibres can give an overall glittery appearance to the fabric. It is cool to the touch and is less likely to be confused with real silk. During washing, acetate fabrics wrinkle very easily and these are extremely difficult to remove. Acetates can also become sticky at warmer ironing temperatures, although they have better sunlight resistance than nylon or silk. Acetate may initially shrink from a flame, burns quickly and can drip. It resists mildew.

## Identifying synthetic fibres

### Nylon

DuPont launched nylon onto the American market in 1938 after several years of development following their discovery of nylon 6-6 in 1935. DuPont decided to concentrate on producing a high-quality yarn specifically for full-fashioned hosiery manufacture. It had a combination of properties unlike any others used during the 1940s as it was stronger, resistant to abrasion, had excellent elasticity and could be heat-set, perfect for gossamer-sheer fabrics. Produced in monofilament, multifilament and staple, nylon is a polyamide and made from a variety of substances (including carbon and adipic acid).

Due to its high strength and resistance to chemicals, nylon was also used for ropes, cords and parachutes, and was diverted to wartime uses solely, from 1942–45. It has also been very successful in the knitting and hosiery industries due to its lightweight characteristics. Since weakened by sunlight, nylon is not very durable for curtains or drapery. It absorbs dye well in its pre-spun state and is also termed a *colour scavenger* as it can pick up colour or dirt from other fabrics if washed together in warm water. Intended as an alternative to silk, nylon introduced the idea of easy-care garments and by not registering 'nylon' as a trademark, DuPont made it a generic term for all to use.

### Identifying nylon

Under a microscope standard nylon has a round cross section and uniform filaments, which are generally transparent. The uniformity of nylon's fibres is a disadvantage in that woven material had a tendency to look flat and lifeless so manufacturers changed the shape of these fibres to suit the product i.e. nylon carpets have a mix of square fibres and voids to provide soil-hiding characteristics.

Nylon has low absorption capabilities and therefore dries quickly and needs to be ironed at a low temperature. Whites can discolour/yellow through washing in hot water and it can have a problem with static. Nylon fabrics have mixed success with drape and body due to its inherent bounce. They are resistant to attacks from insects, rots and mildew. Nylon melts in a flame, self-extinguishing and forming a hard bead that emits a celery-like odour.

### Polyester

The first polyester fibre, Terylene, was produced in England in 1941 by John Rex Whinfield and James Tennant Dickson, two researchers within the Calico Printers Association (CPA). ICI negotiated a twenty-year worldwide license with the CPA in 1943 and was soon negotiating with DuPont who wanted to obtain the U.S. rights to this new fibre. The relationship did not last more than five years during which time DuPont introduced polyester to the U.S. in 1946.

Polyester is a long-chain synthetic polymer produced by reacting dicarboxylic acid with dihydric alcohol. The fibres are melt-spun together and retain the shape of the round spinneret hole. They are produced in many different types and are white in colour. It is considered a 'work-horse' fibre as it is extremely versatile and can easily be blended with other fibres. Popular for fashion and work-wear due to its ability to dye well in the bold new postwar colours, print easily and remain wrinkle-free, it is also used for carpets, sunscreens, curtains, bedding and other interior products, often in blends with cotton. Polyester blends well and can have a more natural look and texture and is woven with other fibres.

**Identifying polyester**

Regular polyester fibres are smooth and rod-like in appearance with a round cross-section. It is not a colour scavenger but can tend to look dingy over time. Due to its lack of breathability, it also has a tendency to promote bacterial odour. It is resistant to sunlight and although resistant to acids and alkalis, can be bleached. Its wet strength is equal to its dry strength. Used for both fashion and interiors, it is warmer to the touch than rayon and acetate and some slub-style polyester yarns can look like linen.

## Processing Staple Fibres

**Carding** is the initial step in preparing fibres for spinning by creating a soft and weak cable of fibres called a **carded sliver**. Done by hand with pairs of paddles with projecting wires, then increasingly by machine as the nineteenth century progressed, the carding machine's revolving cylinders can also remove any unwanted clumps or undeveloped fibres.

**Drawing** continues the alignment of the fibres by combining and lengthening several carded slivers using multiple sets of paired rollers, each moving faster than the other and resulting in one **drawn sliver**.

**Combing** is an optional addition to **carding** and produces a smoother yarn with greater fineness, evenness and strength by removing further short fibres and aligning them in parallel. These sets of fibres are called a **combed sliver**. Almost one-fourth of the fibre is combed out as waste as this stage and reprocessed into **short-staple carded yarns**. Wool or wool-blended yarns that have been combed are termed **worsted yarns**. These have all short fibres removed and the remaining ones are aligned in parallel. **Woollen yarns** are not combed and keep their short fibres, some of which lie parallel and others at random.

**Roving** is the result of a process of hand rubbing or further machine drawing that increases fibre alignment further, reduces the size of the sliver and adds a small amount of twist into the section of fibre in final preparation for spinning.

### Spinning

Shorter staple-fibre rovings are spun together by a method of twisting and pulling, producing a strong yarn with a distributed tension.

**Throwing** A process originally for twisting silk filaments together; it evolved into the twisting of manmade and synthetic filament fibres and then into forms of texturing.

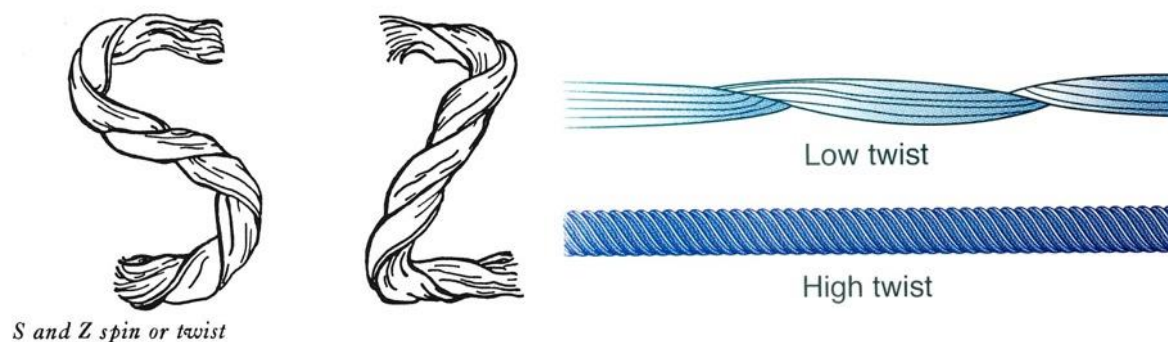

**Twist** The direction of the twist in a yarn is called a *Z-twist* or an *S-twist* yarn. A yarn has an S-twist when the fibres are in a vertical position and the spiral mirrors the central section of the letter S. With a Z-twist the fibres spiral angles downwards following the central section of the letter Z. Different fibre lengths and different yarn types require different amounts of twist. The correct amount of twist for each fibre type will increase yarn strength and also affects hairiness, dye absorption, light reflection and linting.

## Yarn

How a yarn is spun and woven, and how the cloth is finished, greatly contributes to the final production of cloth and is a key consideration during design and manufacturing.

There are two main types of yarn, staple yarn and continuous filament yarn. Staple yarn is created from shorter fibres of one to five inches in length (natural, man-made or synthetic) that are spun together to produce one length of strong yarn. For continuous filament yarn see **Man-Made & Synthetic Fibres**. An exception to this is silk, which is a naturally occurring continuous filament fibre.

**Monofilament yarns** do not have a twist although some modern monofilaments now have the twist pattern formed during their manufacture. These can easily be seen with modern synthetic sewing threads. **Soft twist** yarns have fewer twists per inch and **hard twist** yarns have many more. Specifically made **crepe yarns** have the highest number of twists per inch and can knot and kink once removed from a fabric.

**Ply** A ply yarn is composed of two or more singles that are twisted together to create a numbered ply e.g. 2-ply, 4-ply. The more singles used to create the final yarn, the greater its strength due to the combination of twists. The twists in these singles may be S or Z.

**Slub yarn** is a simple yarn with thicker, loosely twisted areas and creates the textured effect in **shantung silk**. A **nub yarn** or knop yarn is made from two yarns, one coarser, more hard-twisted and plied continuously and at greater speed than the second yarn, which is delivered slowly at intermittent speeds, resulting in uneven take-up. A **loop yarn** is also made of two yarns and rather than knops, has loops at regular or irregular intervals. Do not confuse this with a looped yarn that is created through a woven structure and is anchored in a ground fabric, such as terry towelling. A **flock yarn** is another simple yarn formed from loose fibres (**noils**) that are randomly secured with a twist. The Donegal tweed is woven from this type of yarn. A **core yarn** is where one yarn completely wraps another yarn and is usually made from two different materials to each other. An example of this could be metal thread (see special yarns).

## Special yarns

**Metal thread** is the term used for a core yarn (usually silk or linen) that is wrapped with a fine strip of metal (usually silver or gold). This is not to be confused with the twisted gold leafed paper technique where fine strips of this paper were wrapped round a silk core thread (usually red) to form a supplementary yarn: popular in Far Eastern textiles during the seventeenth to nineteenth centuries and appearing in Western textiles in the years around 1875. The cloth of gold, woven for the coronation of King Edward VII by Warner & Sons, was made using a yellow silk warp and metal thread with a silk core: the metal itself constituting 92 per cent silver and 8 per cent gold.

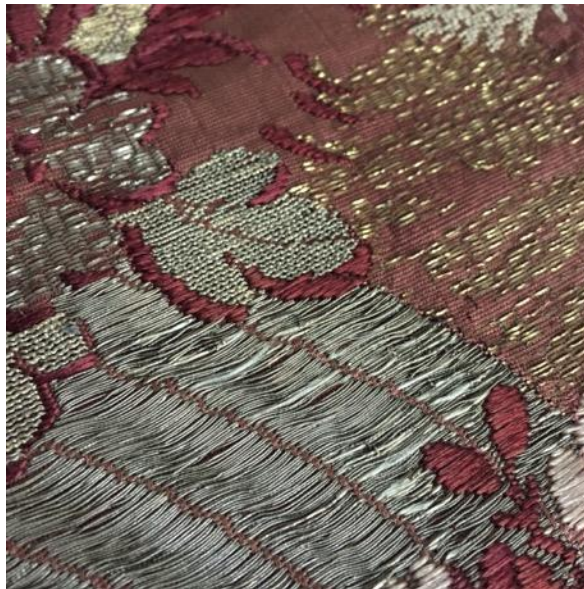
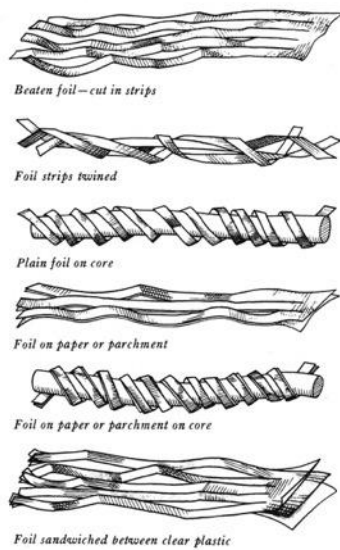

**Bouclé**, from the French word meaning curled or buckled, is a curly or knotted yarn made with two foundation fibre threads that are twisted together with a thicker and coarser yarn that is fed into the twisting process at a faster rate, and in the opposite direction, creating a decorative surface loop.

**Bourette** is a coarse silk yarn that is spun from the waste silk that is not suitable for spinning into schappe silk. Its texture is very irregular and wastes from the noils are dispersed along the yarn length.

**Chenille** Deriving from the French word for caterpillar, this is a yarn that is created from a spaced-warp fabric, cut in the vertical spaces between the densely packed warps into strips. The cut ends along the sides of the strip start to untwist (although secured along their centres with the warp threads) and when spun create a soft fringe-like effect. Chenille is a type of yarn and not the name of a type of fabric.





## 4. Looms

The minimum requirement of a loom is to provide a tensioned **warp** (thus fixed into the loom) and means by which these can be lifted in the desired order to allow the insertion of the **weft** (which is carried on a hand bobbin or shuttle). Loom developments are introduced in chronological order below.

**Dutch engine** During the sixteenth to eighteenth century knitting frame-related adaptations were made to hand looms, in particular those for small textiles such as ribbons, braids, chenille yarns and tapes. The Dutch engine or **engine loom** was developed during the seventeenth century to make these small wares: a reminder that the term 'engine' at this time was not used to describe a mechanically-powered device. It allowed the weaver to produce from 8 to 40 ribbons by using separate shuttles for each ribbon instead of the traditional process of weaving one ribbon at a time.

**Swivel loom** Towards the end of the seventeenth century small improvements were made to the Dutch engine that resulted in the swivel loom, which produced finer products throughout the eighteenth century. Used to weave small patterned cloths such as dots and sprigs, the swivel loom had separate shuttles for each line of the pattern, which were thrown only when required – resulting in a more economical use of yarn. The attached moveable frame allowed one shuttle to insert the ground and the other shuttle or shuttles to insert numerous wefts to form identical patterns across the cloth. The swivel refers to the small shuttles that fitted in these moveable frames.

**Draw loom** Larger-scale patterns during the sixteenth to eighteenth centuries were woven on a draw loom, which already had some ten centuries of use in the Middle East and Asia. It had two separate systems of harnesses within the same loom. The warp passed through both sets of harnesses, being held in place by a thread *lish* (heddle with a central eye through which warps were threaded). The first, or pattern, harness was for producing the fabric design, while the second produced the ground pattern via foot treadles. Although each warp thread could be lifted individually, in practice they were grouped by being connected to leashes passed up through a comber (pierced) board, which represented one entire pattern. Beyond this the leashes were attached to another set of cords down the side of the loom, which form the *simple*. The simple was operated by a *draw boy* who knew in which order to 'draw' the cords down by a tagging or numbered system.

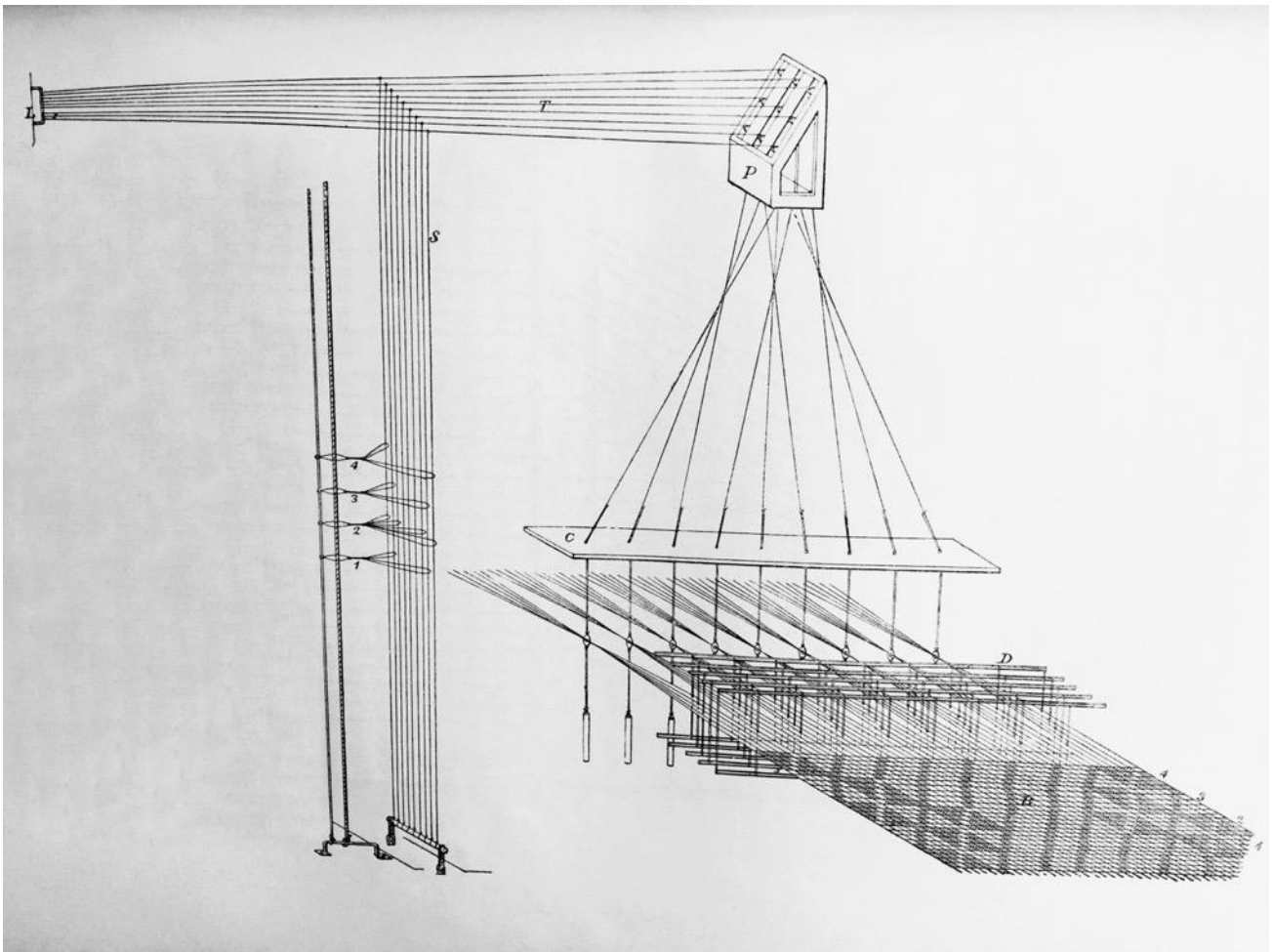

### Diagram of draw loom

**B** = Pattern – fabric design

**D** = Heald / Healdle / Heddle – through which the warp threads pass through. These can be made up in various ways but most common is where the heald consists of two laths, between which are stretched the number of required leashes. These are usually made of linen thread and have an eye formed in them in the middle; either looped yarn, made of glass or steel. A very small eye is called a 'mail' and is normally used in silk weaving.

**C** = The Leashes that pass through holes in comb board for purpose of keeping them in position. The leashes group the warp threads together.

**P** = bottom board of Pulley box

**L** = Staple – where leashes are collected together

**S** = Cords – form the Simple

**T** = Tail of harness

**1, 2, 3, 4** – correspond with section of pattern and relevant group cords that pull the Simple.

**Lappet loom** During the eighteenth century, mainly in Scotland, the lappet loom was also weaving plain or gauze weaves with small patterns, created by zig-zagging supplementary warps controlled by a bar of needles swung back and forth where needed, allowing the weft to catch down this extra warp. The action of the needle bar was controlled by a lappet frame attached to a grooved ratchet wheel, one revolution of which represented one pattern repeat. The results resembled embroidery. It continued to be used for manufacturing specialist products into the twentieth century.

**Jacquard loom** In 1801 Joseph Marie Jacquard exhibited his new loom at the National Exposition, Paris, after eleven years of developments based on M. Bouchon's loom of 1725, which required a band of pierced paper to activate hooks. The Jacquard machine required further improvement and by 1835 was essentially an upper frame containing one loop of punched cards for the pattern and another, much smaller set of cards, for the ground weave. Warps were lifted where required by being threaded through a heddle, itself attached to cords, hooks and – at the top – metal rods. When the treadle was depressed by the weaver, all rods were pressed upwards, but only those encountering a punched hole could rise to lift a warp thread.

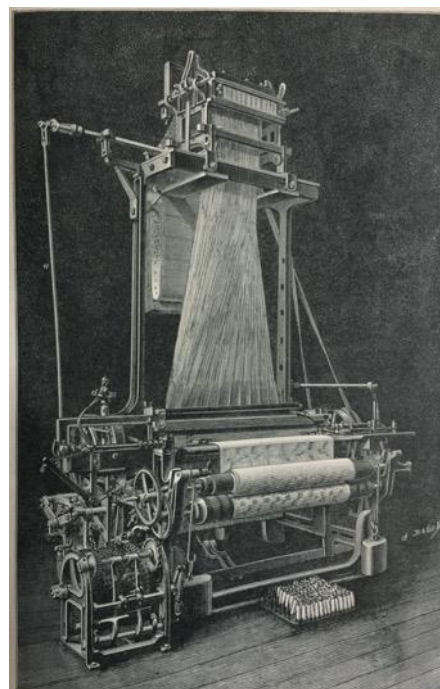
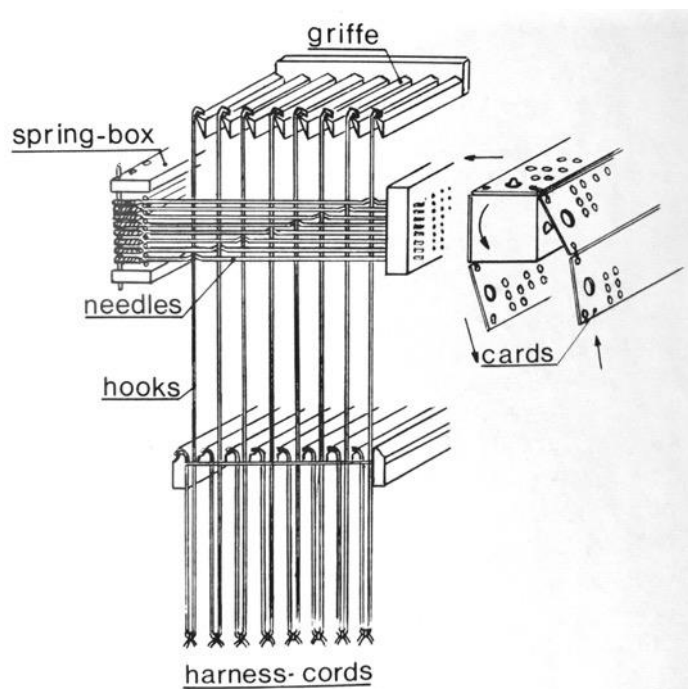

The Jacquard machine replaced the draw loom apparatus and draw boy and in its advanced form was almost unlimited in its capabilities. Those with 600 and 900 hooks were mainly used on hand looms for weaving figured silks. A common handloom with a 400 hook Jacquard, at 400 warp ends per inch, woven at a width of 24", required 9,600 heddles. It would not have been possible in practice to operate 9,600 separate hooks, so they were often divided into more manageable groups in accordance to the number of pattern repeats across the fabric width.

**Dobby loom** Fully developed by *circa* 1840, this loom operates on a peg system that threw in or out of action a series of hooks or bars, which lifted the shafts, the pegs were placed in the pattern of the design, called a peg plan. These were then joined together to make a continuous chain called a lag, which was rotated through a box on the top or side of the loom by depressing the treadles. Typically with eight shafts, but capable of operating up to 16 or more, this loom, especially once mechanised, specialised in weaving smaller all-over patterns, called **dobby weaves**.

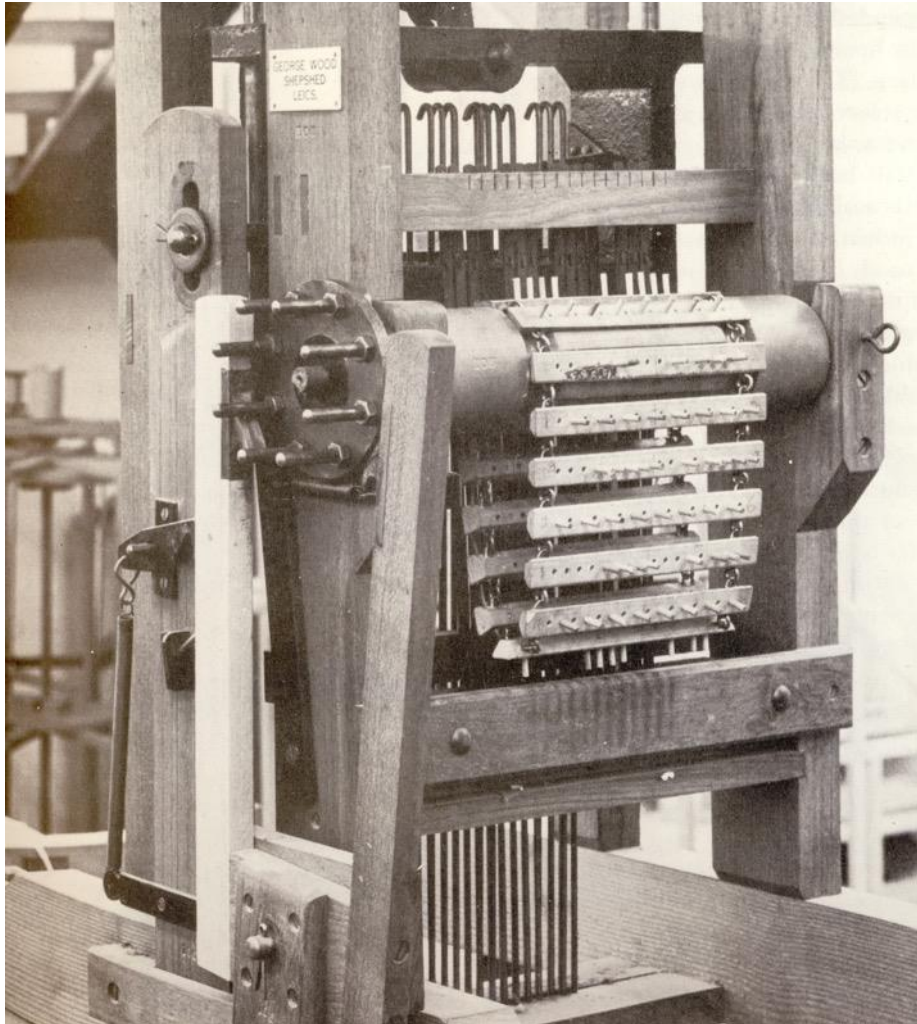

**Power looms** Although a model loom was built during the seventeenth century for weaving cloth 'without the aid of a workman' and similar additions during the eighteenth century, such as Vancuson's trials of a self-acting loom in 1745, the power loom revolution was one of exceedingly slow growth. The first attempts, patented by Edmund Cartwright in 1790, adapted the handloom and was an effective way to mechanise the process of lifting the shafts, winding on of the cloth and throwing the shuttle from side to side. A year later Richard Gorton patented an automatic stop motion, activated when a warp thread snapped or a shuttle failed to be thrown.

The introduction of metal parts was crucial in developing viable power looms. For example, a **tappet loom** had metal tappets within a wheel that were directly linked to the number of shafts (usually between 2 and 5 and no more than 8). Modified in 1820 and then again in 1822, the tappets were shaped and when turned, depressed the connected treadle, which in turn raised the connected shaft. It was used to make **simple weaves**.

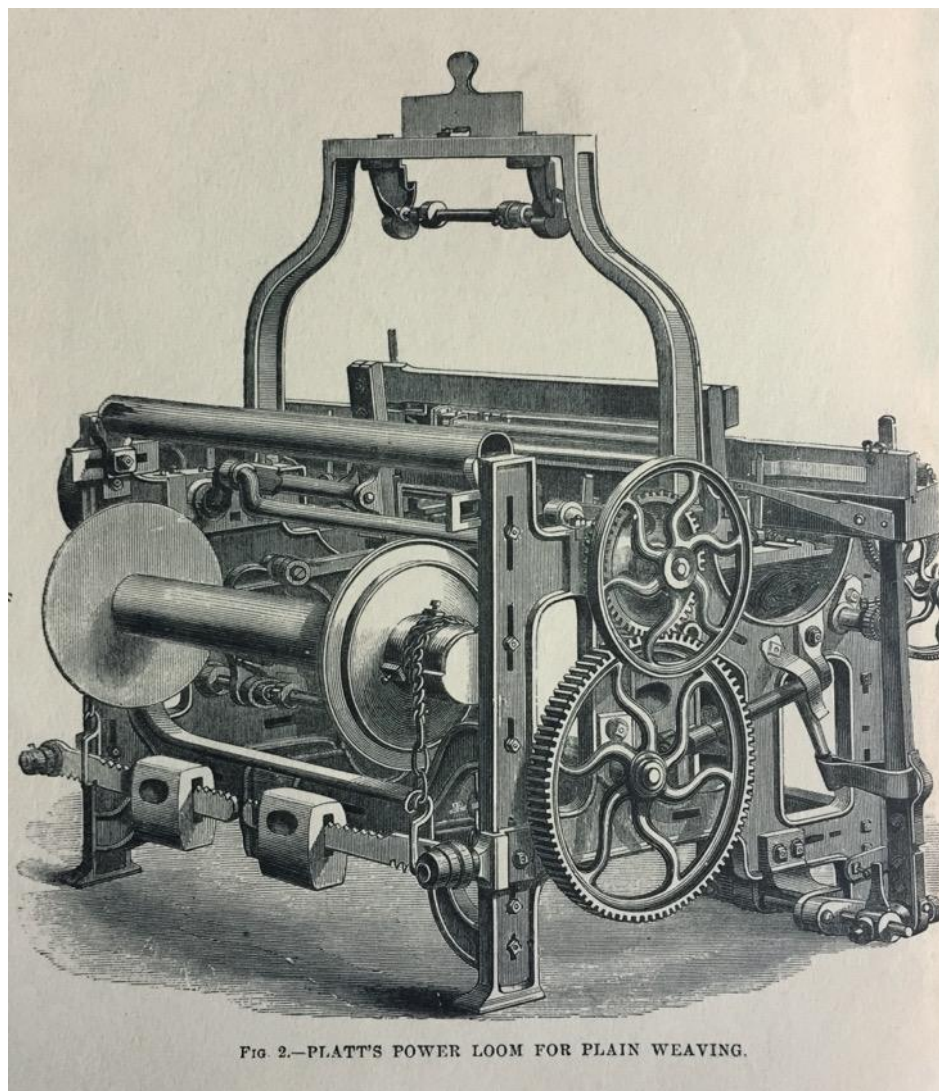

The first steam loom had been invented in the 1820s but it was not until the 1860s, when steam power was more broadly introduced, that the power loom truly began to replace the handloom. Such looms – the most popular of which was the dobby – were formerly powered by means of friction and clutches but by the third quarter of the nineteenth century fast and loose pulleys, attached to a common drive shaft, were in wide use. The automatic stop for broken threads had been improved by 1834, in a patent by Messrs Ramsbottom and Holt, with further improving patents taken out in 1839 and 1840. The hand Jacquard mechanism, patented in the UK in 1820, was not widely adopted until the 1840s, when all of these improvements came into play and it too was fitted to power looms. In Jacquard power looms, those with 300 hooks were most common.

## 5. Finishing

Finishing is a term used for the process or processes applied to a woven or printed textile once it has been taken off the loom or print table. There are many different ways to finish a woven textile and in certain circumstances these can almost transform the cloth. These processes can be expensive as they are labour intensive and use significant quantities of water and energy. Below are examples of finishes that are most common between our dates of 1750–1950

**Calendering** Fabric is passed through a series of rollers turning at differing rates, through which friction and heat can be used to create a variety of finishes. A *simple calender* produces a smooth and completely flat, firm finish. In this process, the fabric is slightly damp when fed into heated rollers, which travel at the same speed to avoid friction.

**Devoré** This technique is mainly used on velvet fabrics made with fibres of different constituents so that only one will be destroyed in the process. For example, when a design is printed with a chemical solvent on to the surface a silk pile, the solvent-reactive fibre (silk in this example) is dissolved leaving the ground fabric which must not be a protein fibre, but rather of cellulose (and today is often nylon) It can be used on fabrics with or without pile including satin. The technique was developed at the end of the nineteenth century, being adapted from the making of chemical lace, and was particularly popular during the 1920s and 1930s. It was made in imitation of **ciselé** and **voided velvet**.

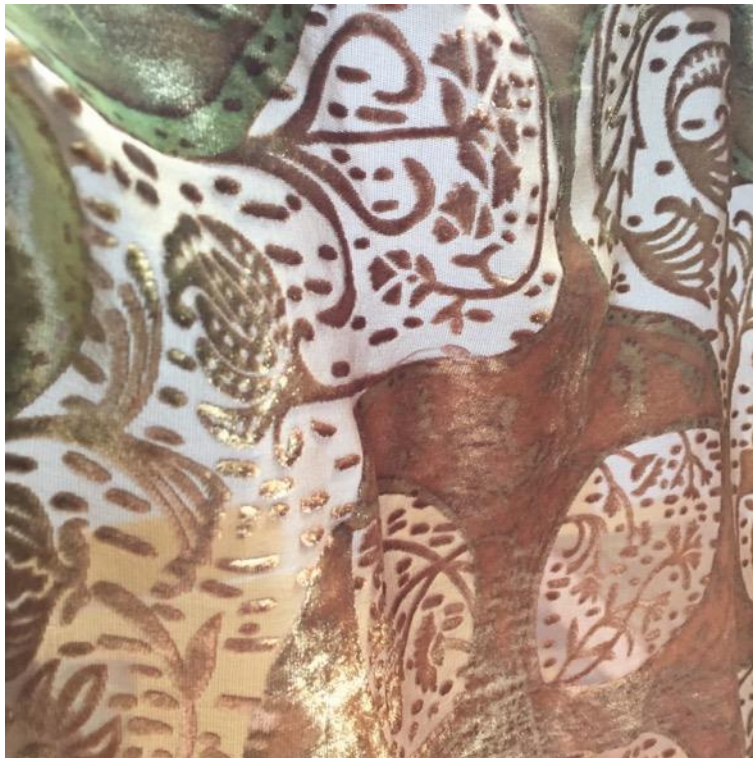

**Embossing** A heated metal patterned roller is pressed over a fabric to produce flat or raised areas corresponding to the design on the roller. The hot engraved areas of the roller create a slightly glazed area on the fabric. The two main rollers are flat embossed and raised embossed designs and they can be used on a flat textile or one with a pile. With heat-sensitive fibres it can produce a durable finish. Mohair velvets were a popular embossed fabric during the nineteenth century and many still retain the vibrancy of their original manufacture. The same effect was originally obtained by stamping with wooden blocks as illustrated below.

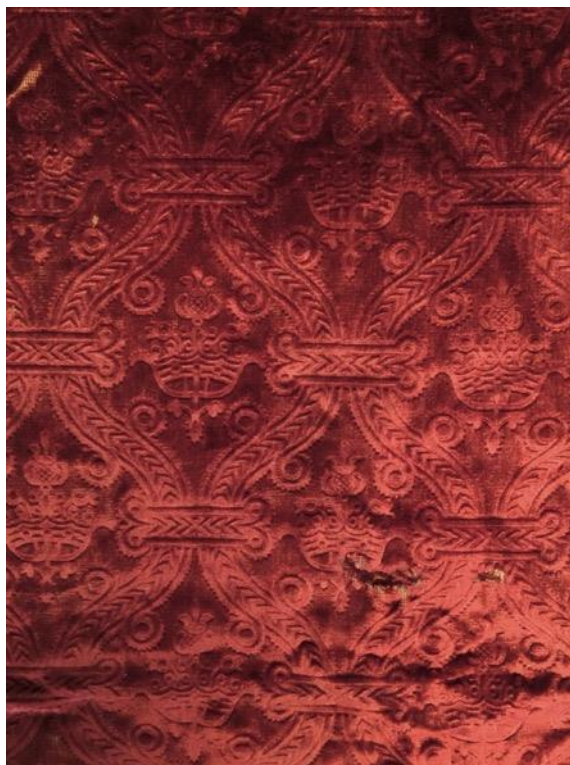

**Fulling** Wool fabrics for fashion and upholstery look very different in their loom-state and the fulling process helps to improve their appearance, softness, body and cover. Heat, moisture and gentle friction are applied to wool textiles in a controlled process creating a dense and more compact cloth. Almost all wool fabrics and some knitted fabrics are fullled.

**Glazing** Surface glazes add a reflective polished finish to a plain-woven cloth, most often cotton with a printed pattern. Other fabrics such as some linens and wool can also be glazed. One method is to soak the fabric with starch and waxes (which creates a semi-permanent finish); another is to use a resin (which makes a durable glaze). Before the fabric is fully dried it is passed through a friction calender to produce a highly glazed surface. Other substances that could be used to create this finish were egg whites, gum Arabic and shellac. A **Ciré** finish is similar to a glazed finish and is achieved by heating the calender roller to a higher temperature to create a high gloss finish. The technique was originally only used on silk but was taken up very quickly by rayon manufacturers where the rayon fibres slightly fuse together creating a finish called **wet-look**.

**Moiré** creates a watermarked appearance and is traditionally made by passing two layers of an unbalanced plain weave ribbed fabric (such as **repp** or **grosgrain**) through smooth heated rollers under pressure. The two layers of fabric are forced to move off-grain to each other allowing the rib in the weave structure to move, creating a watermark pattern on the facing sides of the fabric.

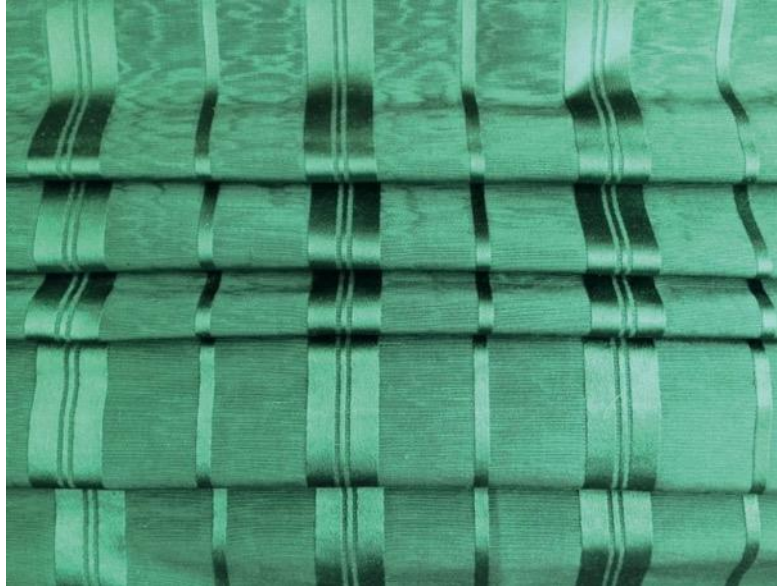

**Napping** The nap is the layer of fibre ends that stand proud from the woven ground. With some cloth the nap is part of the fabric structure, for example **frisé** (a fabric with a long uncut nap used for upholstery and rugs). Napping was originally brushed by hand using teasels or dried plant burrs. Nap can also be trimmed to create a fine surface layer or into patterns for a three-dimensional finish.

**Plissé** The application of caustic soda via a printing process in the form of a pattern is applied to a woven textile. The areas of cloth exposed to the caustic soda crinkle or **plissé** in the desired pattern. It is more successful with finer fabrics such as silk and percale and for woven accessories such as ribbons. Stripes were a common pattern and plissé fabrics were popular as a fashion textile during the mid- to late-nineteenth century. Plissé must not be confused with seersucker or embossed fabrics.

**Weighting** The process of removing natural gum from silk means the fabric can weigh up to 15 per cent less. The technique of **weighting** silk by manufacturers has been popular for centuries and is a process where woven unfinished fabric was passed through several baths of metallic salts such as iron sulphate or minerals such as stannous (tin) chloride. Some types of salts are more durable as they bond with the fabric fibres while other salts create a temporary surface coating. Weighting silk adds fibre volume, lustre and handle but is very taxing to the fabric itself. Mineral-weighted silk was traditionally the most common but is a rare process today. These types lose strength after coming in contact with air, light and moisture. The life of a weighted silk can be reduced from years to only a few months since the fabric will fracture and disintegrate. When exposed to a flame tin weighted silk does not crisp and leaves a black ash after burning that looks like a thread. Iron weighted silk leaves a soft white ash after burning which smoulders. French nineteenth-century silks were often weighted, whereas those made in England, especially Spitalfields, were not.



## 6. Identifying Weaves

### Simple Weaves

Weaves can be divided into three categories – simple, dobby and complex. The simplest and most widely used weave structure (**plain** or **tabby** weave) has yarns in the loom (the **warp** or end) spaced at intervals roughly equal to those in the **weft** (also pick or filling), which is passed back and forth under each warp and reversing the over-under sequence on the return journey.

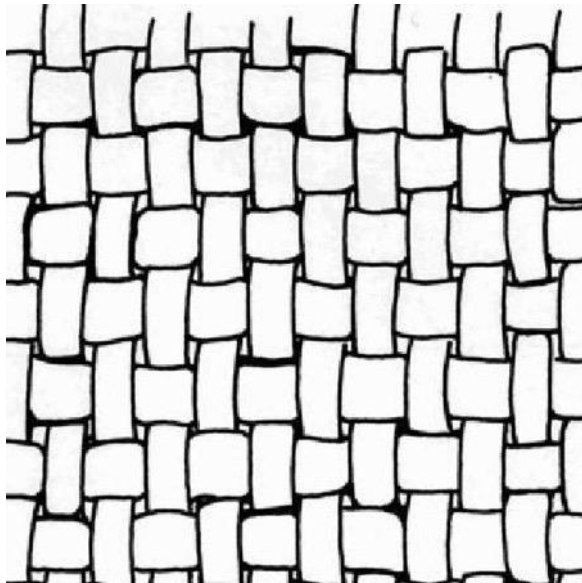

The cloth is identical on both sides. In balanced plain weave the warp and weft diameters are identical or nearly so; 'faced' plain weaves such as **poplin** have fine yarns on the surface and thicker ones beneath. Texture and pattern can be added by way of textured yarn or using different coloured threads (warp or weft) to produce checks or stripes.

A wide range of cloths are made in plain weave and their names often distinguish the weight and density of the fibre or the finish of the cloth. These include some tweeds and:

**Baize** A loosely-woven cloth with a worsted weft and softly-twisted woollen wefts, and a 'napped' or brushed finish. Today the thicker furnishing variety is associated with billiard tables but when introduced into Britain from France in the sixteenth century the lighter variety was used for clothing. The region from Colchester to Braintree became known for its manufacture.

**Broadcloth** Today often denoting a cotton fabric, from 1750–1950 it generally meant a stout woollen cloth made from fine merino yarns, and heavily milled and finished to produce a lustrous smooth-faced, dense fabric with a velvety feel. Until *circa* 1900 also used to indicate garments worn by the clergy.

**Calico** a tightly-woven cotton that is unbleached or unfinished, this is the cloth from which fashion toiles are made, and that forms the basis for printed cottons.

**Canvas** A strong, firm and closely woven cloth, now usually of cotton but prior to *circa* 1800, of flax or jute. Also known as **Duck** after the Scottish trademark picturing a duck on the heavier weights of flax sail-cloth.

**Challis** A lightweight wool cloth that is soft and supple in the hand. Typically printed, it originated from Norwich in 1832 and in the twentieth century began to be made of rayon staple.

**Lawn** A very fine plain cloth, originally with an open texture made of fine linen yarns (now known as 'linen lawn') but becoming a cotton cloth by the 1830s. Although sheer, it is compact in construction and 'crisper' than **voile** (made of hard-twisted yarns) but not as crisp as organza.

**Muslin** A firm, cotton cloth varying in weight from semi-sheer book muslin to heavyweight sheeting. When associated with window curtains from *circa* 1790, the word indicates the sheerest type. While machine spinning developed (*circa* 1785–1830s) the term applied both to very fine, strong white cotton yarns and to any cloth made from them, including those with raised self-coloured spots or stripes, which became known as **Dimity**. **Mousseline** is the most delicate muslin and until *circa* 1820 was only available from India.

**Organdie/Organza** Fine and light, organza is traditionally made of silk and has a stiff, crisp finish. Organdie (Organdy) is not finished, or only lightly, and is more pliable. Both have more warps than wefts per inch, with the wefts being composed of finer threads than those in the warp.

**Taffeta** Crisp, closely woven cloths of silk or silk-like fibres such as rayon. With an even number of weft and warp threads per inch, it has a slightly stiff crisp papery feel.

**Tapestry** True tapestry is handwoven and has its warp completely covered by wefts of different colours, worked only where they are needed to form the imagery. The drawings for tapestries are called 'cartoons'.



Among the variations on plain weaves are stripes, as well as:

**Basket weave** A simple weave, usually in cotton or linen, which employs an over-under combination of equal number warps and wefts (usually two, three or four) to create a coarse surfaced cloth which resembles basket-work.

**Chambray** Initially of linen, this fabric originated in Cambrai, Northern France, where the fabric was used to create sun-bonnets. The warp thread is of one colour and the weft thread is always white. By the late nineteenth century the term was applied to cotton fabrics made in the same way. **Cambric** is named after the same French commune; it was woven in greige, then bleached, piece-dyed and often glazed or calendered.

**Chiné** A silk fabric with a shadowy effect around the design produced by resist dyeing the warp threads prior to weaving.

**Gingham** A plain-woven cloth with white and dyed yarns arranged in stripes or, more usually, balanced checks. From 1750 until *circa* 1800 these were of linen or a linen warp/cotton weft combination called **fustian**. Thereafter ginghams are increasingly all cotton cloths. The widths of the checks can be many sizes and the cloth itself of differing qualities. Typically, this cloth is hard wearing, cheap to produce and is often used for work clothes or upholstery cloth. Several origins of the name gingham have been suggested including Guingamp in Brittany, where gingham was once manufactured extensively. However, the *Oxford English Dictionary* derives the word from Malay 'ginggang' meaning striped.



## Ribbed plain weaves

Ribbed plain weaves are generally called **repp**, with a pronounced horizontal rib created by including coarse threads in the weft.

**Grosgrain** A firm and closely woven ribbed fabric or ribbon made with wefts that are heavier and tighter than **poplin** and rounder than **faille**.



**Poplin**, another repp variant, is a tightly woven fabric that has a subtle ribbed appearance created by using tightly woven fine warps and less tightly woven thicker yarns in the weft. The principal type is **Irish poplin**, with a silk warp and worsted weft, which was a widely used fashion fabric from 1750–1950. By the end of the nineteenth century, cotton poplins had begun to replace fine linens for items such as dress shirts. Also called **tabinet** (or tabbinet).

**Ottoman** has the most pronounced horizontal ribs and is a firm fabric that cannot be gathered or Shirred. It has two fine warps (originally of silk, giving its characteristic sheen) and a thick 'filler' weft entirely covered by the warps, so the weft is not seen on either the front or back.



**Watered cloths** Worsted repps typically receive a stamped or embossed figure; silk repps when folded and calendered create **moirés**.

## Textured Plain Weaves

**Bourette** A fabric with a rough, knotty surface resulting from the incorporation of a warp of linen and weft yarns spun from the coarse outer fibres of cocoons. It was being woven by at least as early as 1730. It later became known as a lightweight, rough-faced dress cloth with bourette yarn employed in either twill or plain weave.

**Chiffon** The softest and most flimsy of cloths in a plain weave structure. Primarily of silk, chiffon is lightweight, extremely sheer, transparent, airy, and soft, containing very fine, filament yarns (so from *circa* 1925 also incorporating rayon). Both the warp and the weft threads are heavily twisted ('hard spun' or *crêped*). It is a balanced cloth, with approximately the same number of warp and wefts, both of the same size. However, these are alternating S- and Z-twisted yarns, which relax after weaving and pucker the fabric slightly in both directions, giving it some stretch and a slightly rough feel. The finish is dull. Also called **Chiffon crêpe**, it is similar to **georgette** but softer. The name is derived from 'chiffe' the French word for rag or flimsy cloth. Merriam-Webster gives 1765 as the date of its first known use.

**Crape** typifies the challenge when defining textile terms. It is an alternate spelling of *crêpe* but in the eighteenth century also referred specifically to a woollen fabric, either crimped for mourning or plain. In addition, when in 1825 Samuel Courtauld's brothers George Courtauld and John Minton joined the family firm, they started weaving a crape defined as a crimped silk **gauze**, for which they invented an embossing roller.

**Crêpe** A general term used for all cloths made with a textured, crinkled, wrinkled or grained matt-surface effects. The cloth can be made from a combination of many yarns. Predominantly used in the nineteenth century for mourning dress. Special hard-twisted yarns are used which shrink when washed to create its puckered and crinkled surface See also **Crape**.

**Crêpe-de-Chine** A soft, thin, opaque and lightweight fabric with a crinkled effect. It is woven with alternating 2S and 2Z highly-twisted weft threads and untwisted warp threads. There are many more warp ends than picks per inch. A lustre is always visible owing to the fine silk warp.

**Georgette** A fine sheer *crêpe*-weave fabric originally of silk but now of silk, cotton, rayon or a mixture of these fibres. Although the characteristic crinkly surface is also created by alternating S- and Z-twist yarns in both warp and weft, the cloth is more 'grainy' than *crêpe*.

## Open Weave Fabrics

**Aertex** A tradename for a cloth patented in Britain in 1886 by the Cellular Clothing Company and first manufactured in 1888, this cloth employs both **basket** and **leno** structures to create what appears to be an all-over diamond course of threads, on top of an open-work basket weave. Its insulating properties made it an important fabric for under garments, corsetry, sportswear, sleepwear and blankets. Aertex itself also began manufacturing such garments in 1891 and promoted its cloth as an 'air-conditioned' cellular fabric.

**Cheesecloth** Lightweight and loosely woven from carded cotton, this plain weave material is often sized or stiffened to retain a gauze-like appearance. Also called **scrim**, when dyed it is known as **bunting**.

**Gauze** A plainly woven cloth using two warp beams, one firmly weighted, with the other being lightly weighted to allow *some* warp threads to be twisted back and forth as weaving progresses (see **Leno**). It was originally produced in Gaza, Palestine. Traditionally woven in silk and later in linen, then cotton, it was widely used for veiling and mosquito netting. During the late eighteenth and early nineteenth centuries it was made in Spitalfields, London, for dresses, and often incorporated metal threads. Although surgical bandage is often referred to as gauze it is in fact plain woven fabric similar to cheesecloth.

**Leno** Made with two paired warps twisted back and forth around the weft thread, true leno weaving requires a dedicated loom with two harnesses. One is called a **doup** harness (since the warp thread that twists alternately left and right is termed a doup thread).

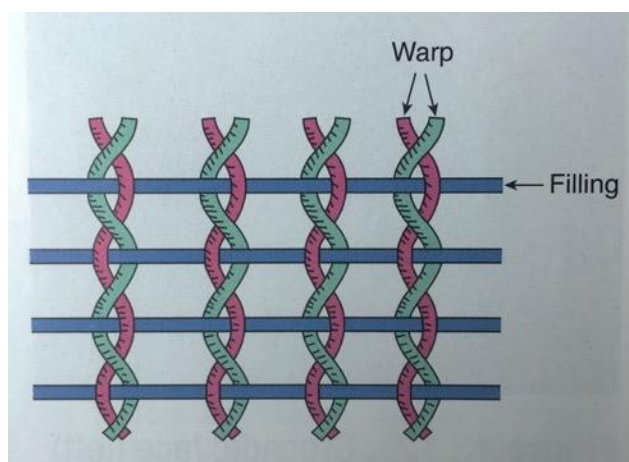

**Madras Gauze** (also known as **Scotch Leno Madras**) A lightweight cotton with a leno ground and patterns formed with a much thicker weft. The latter is left floating between motifs and cut away after weaving, leaving characteristic “fringing” around the patterned areas. Originally from Madras (now Chennai) in India, its weaving became a substantial industry in Ayrshire by the second quarter of the nineteenth century.



**Mock Leno** Woven without twisting any warp threads, but retaining the characteristic open spacing of lenos, this effect is obtained by irregular spacing of the warp threads as they pass through the heddles. Either warp or weft yarns (or both) need to be textured enough to 'bind' to each other and hold the spaces open.

## Twill Weaves

Twill weaves can be identified by the marked diagonal movement across the cloth created by the sequencing of the weft threads which cross the warps at evenly off-set, vertical intervals (from left to right or from right to left). The sequencing of interlacing can vary – this diagram shows a 3/1 twill which has three wefts passing behind one warp before it is bound in place by a single warp; '3/1' and similar notations thus describe the number of wefts each warp end floats over in a weft faced twill. Among the many twill weaves are:

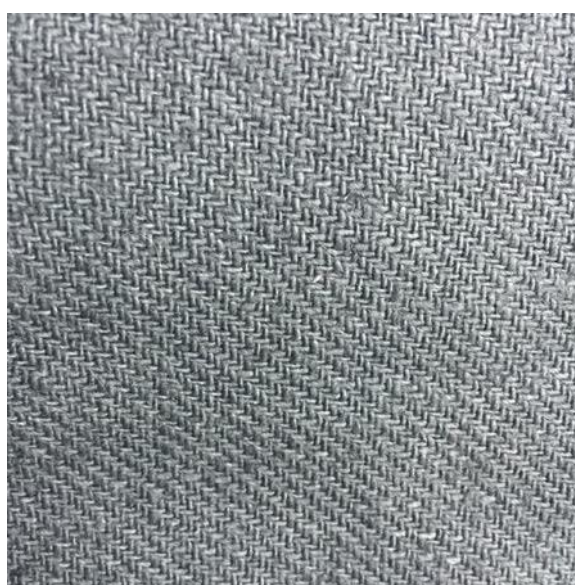
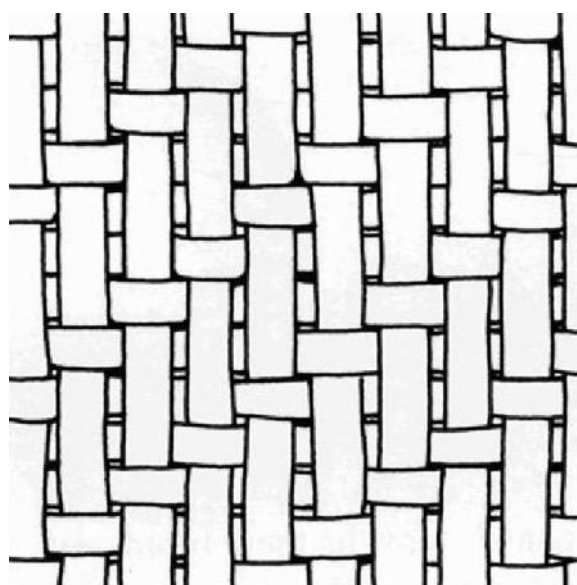

**Denim** A strong yarn-dyed cotton fabric with a warp-faced 2/1 twill, or a 3/1 twill in heavier weights. Blue denim is composed of an indigo-dyed warp and grey or unbleached weft, producing its characteristic appearance, described as 'white-back'. Brown denim is similarly white backed. Derived from 'serge de Nimes', the term is noted in the *OED* as 'serge denim' in 1695, when it was a worsted cloth; all-cotton samples (including some with stripes) were made in Lancashire by at least 1786, when they appear in the Hilton manuscript (PRO).

**Houndstooth** This cloth is normally produced using worsted yarn and is achieved by a combined colour and weave effect. The twill structure can be produced by either 4+4 or 8+8 contrasting threads in the warp which are crossed with a similar weft thread arrangement. This structure forms a jagged edge check cloth that is often found in suiting. During the late nineteenth and twentieth centuries the cloth was also referred to as Shepherd's Check.

**Harris Tweed** A fabric defined for the purposes of the trade mark of the Harris Tweed Association as 'tweed, hand-spun, hand-woven, dyed and finished by hand in the island of Lewis in the outer Hebrides'. It is a loosely woven worsted yarn made from pure virgin wool of mountain and hill sheep. The cloth is a two and two twill structure woven on a doobby hand loom or power looms (Hattersley). During the finishing the cloths are dried in a loft heated with peat fires. This gives a peculiar odour to the cloth.

**Foulard** A lightweight, lustrous silk originally from India, woven with a two up, two down twill. Typically printed with small motifs on a solid-coloured ground (though occasionally entirely plain and now made of many other fibres), it remains popular for neckties and pocket hankies, as well as dresses, robes and scarves.

**Gabardine** Tightly-woven, warp-faced fabric with a 45- or 63-degree angle twill. It has about twice the number of warp threads as weft threads and the twill is distinctly raised on the front, but not on the reverse. Frequently made from a worsted wool warp and a linen-then-cotton weft (although all-cotton gabardine is now common), its tight weave gives it a smooth flat finish and a degree of resistance to water, hence its use for lightweight, showerproof outerwear. Planché (1876, p.196) notes gabardine as meaning "A rough Irish mantle," "a horseman's cloak," or "a long cassock," according to Blount ('Glosso-graphia'); or "a cloake of felt for raynie weather," according to Cotgrave' and appearing in these forms in the 16<sup>th</sup> century.'

**Serge** One of the oldest known twills and from the Latin *serica*, meaning silk, followed by the Italian *sergea*, meaning wool and silk, the diagonal in serge rises from lower left to upper right and is a 'two up, two down' twill. Woven in any fibre, it is especially associated with worsted suitings.

## Satin Weaves

**Satin Weave** The smooth shiny surface of a satin weave is created by the large surface area of exposed warp threads, which are intermittently bound. They can be woven with the number of harnesses ranging from 5 to 40 (although the latter is rare). This example shows a 5-end satin, in which the densely set warp is held down on only every fourth cross of the weft (four under, one over). This sequence, referred to as a warp-faced satin, can be reversed so that the weft threads form the dominant surface area of the fabric (four over, one under, and called a weft-faced satin). A cotton satin is often called a **sateen**.

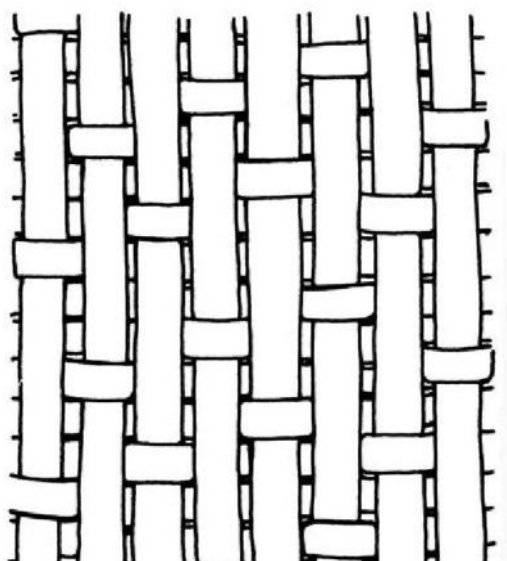



*Fairchild's Dictionary of Textiles* gives more than 100 entries for cloth terms that begin or end with the word 'satin', and describes many other cloths aside from damasks that incorporate this weave structure. Among these are:

**Duchesse** A lustrous silk or rayon dyed in a solid colour. These are made on 8- to 12-harness looms.

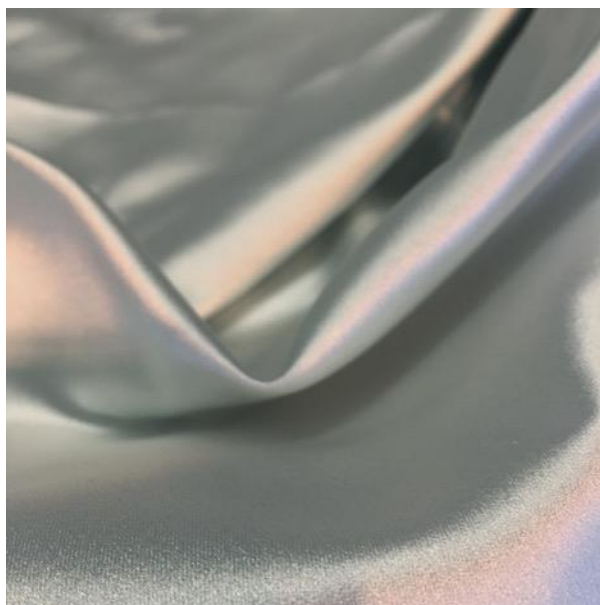

**Satin du Barry** Popular in the early- to mid-nineteenth century, these satins have an alternating black and figured stripe.

**Satin Figaro** A double-faced satin with two different alternating colours in the warp, which as a result presents a 'flickering' colour rather like a warp-printed cloth. French in origin, it was used for dresses and millinery from around the 1770s until the mid-nineteenth century.

**Satin Georgette** Heavy but sheer, this satin is composed of hard-twisted yarns and was introduced in the 1930s for evening wear.

**Pekin** Originally a painted or embroidered silk fabric imported from China and imitated in France from *circa* 1760, as dress goods these had alternating satin and velvet stripes (or a gauze stripe in **Pekin gauze**). Fashionable to the end of the nineteenth century, by this time they were composed of a range of fibres and could incorporate small patterns in the non-satin stripes, but were characterised by equal-width, evenly spaced stripes.

**Taboret Stripe** With alternating satin and tabby (usually repp) stripes, these became fashionable at the end of the eighteenth century and remained so into the 1920s, especially for interiors. Well into the nineteenth century these were often calendered to create a moiré finish apparent only on the repp stripe. The proportions of the stripes are more varied in earlier examples and by *circa* 1900, they are nearly (but not exactly) of identical widths.

## Dobby Weaves

This general term encompasses weaves made on a dobbie loom. Although they may have up to 30 harnesses, the length of the pattern is limited by the number of bars in the dobbie chain. This results in cloths typically patterned with relatively small motifs, and often heavily textured dobbie weaves never employ full width repeats. There are many cloths that can be dobbie-woven and have names related to their principle construction rather than the loom, and this is because their development long pre-dates the mechanical dobbie. See, for example, **Satin Weaves** and **Pile Weaves: corduroy, terry, velvet and velveteen**).

**Armure/Cannetillé** This term is given to cloth which can be woven for either dress or furnishing. The word is a derivation of the French word 'armour'. Its woven effect gives a pebble-like appearance with a resemblance, as the name suggests, to chain mail. The cloth comprises of two warps, one lightly weighted whilst the other more tightly weighted. The structure is created by the use of eight shafts, and is also found incorporated into Compound Cloths.

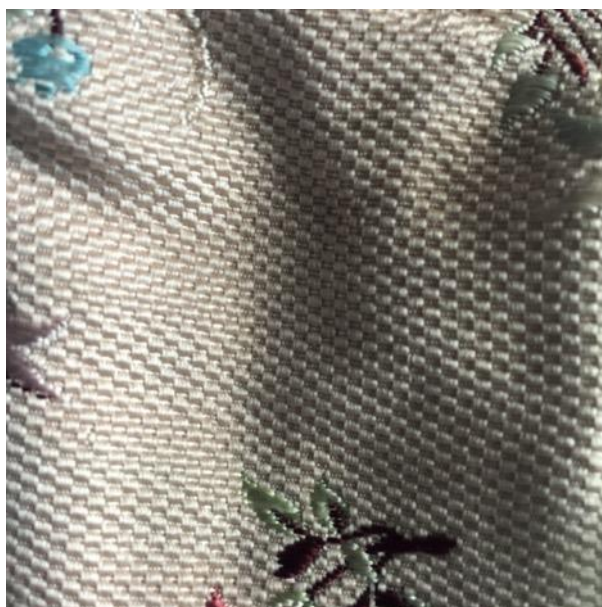

**Diaper** Characterised by the incorporation of small diamond patterns, this cloth has several iterations, including 'diaper linen' (as its name implies, made of linen), a check composed of cotton twill and satin weaves and, originally, a costly texture-woven silk made in Belgium and called 'toile d'Ypres'. It is generally a single colour.

**Piqué** Composed of two warps and two wefts, with the face warp lightly weighted (loosely beamed) and woven with a (plain) tabby weft. The back warp is heavily weighted (tightly beamed) and stitches through the face cloth according to the pre-arranged design. At the stitching points the face cloth is pulled down, causing the face to form an embossed surface. The second weft is used as wadding to make the raised figure more pronounced.



## Pile Weaves

**Corduroy** A cotton fabric with vertical ridges of pile created with supplementary wefts floating between narrow vertical areas in which they are bound down. The floating wefts are slit after weaving and the result is a slightly rounded ridge of pile.



**Manchester Velvet** From the mid-eighteenth century onwards, Manchester became widely known for its manufacture of cotton velvets, which included **corduroy**, **thickset** (a strong corduroy with a short, thick pile used for work clothing) and **velveret** (with a ribbed effect or printed). Numerous examples survive of mid- to late-eighteenth-century swatches of plain, fancy and printed Manchester velvets, largely intended for men's wear, particularly waistcoats, but entire suits were also made from this cloth (see FM).



**Moquette** Also called **Mockado**, this is said in the eighteenth century to have been made entirely with linen but also began to be made during that century, if not before, with a wool or mohair supplementary warp, which can be cut pile or uncut loops but has no voided areas. This term denotes heavy cloths used for upholstery and carpeting.

**Plush** This fabric has warp pile that is longer than **velvet** and less closely woven. As a black fabric these were used for men's top hats in the nineteenth century, but they also may be crushed or embossed with patterns, or multi-coloured when Jacquard woven after *circa* 1835. The term is also used to refer to wool velvets with a pile of worsted or mohair. These could be stamped.

**Terry** Made in the same way as either **velvet** or **velveteen**, terry cloths have no cut pile, but rather have all the loops left intact. This term is most often associated with cotton fabrics that have widely spaced loops, as in terry towelling.

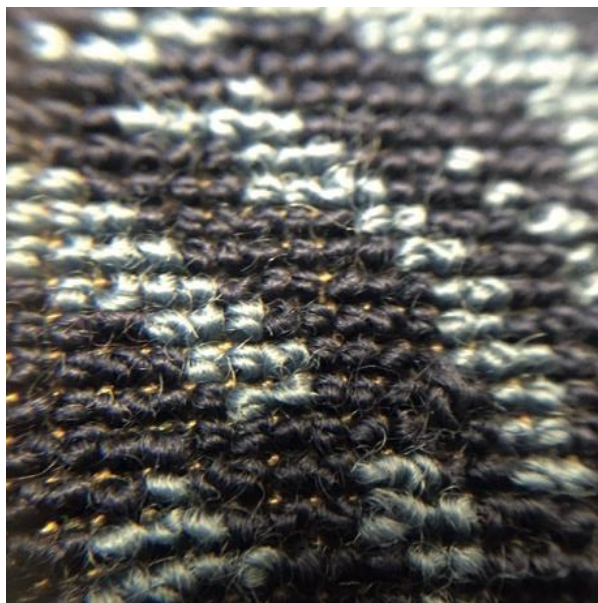

**Velvet** This soft 'fuzzy' cloth has a dense pile formed by supplementary warps. In hand weaving these are looped temporarily over a several weft-ways cutting wires, each secured on either side by several ground wefts, after which the loops are cut open and the wires removed, to be used again as the weaving progresses. Associated with silk, there are many variations of velvet with names indicating different fibre content. These include **Utrecht velvet** (linen warp and mohair pile) and **velour** (short, thick pile, usually of cotton, wool, or a cotton warp with a pile of wool, silk or mohair); both of the latter are generally weightier than silk velvet and may have cut pile or stamped patterns.



**Velvet Ciselé** Also called 'cut and uncut velvet', a ciselé velvet is figured with areas of both looped and cut pile, and normally has voided areas also. Like many velvets associated with silk weaving centres, wool velvets of this type, woven in Spitalfields in about 1760, survive in the Moccasi manuscript (Bibliothèque Forney: 677.064).



**Velveteen** A fabric with a short dense pile made by weft tufts, often referred to as 'cotton velvet' since that is the fibre most often used in weft-based velvets.

**Voided Velvet** A velvet in which a pattern is created by weaving some of the cloth with no pile at all.

## Compound and Figured Weaves

Compound weaves are those woven with warps and/or wefts that are additional to the warp and weft threads necessary for a structurally sound fabric. These types of weaves are used to create more elaborate patterns – and therefore called ‘figured’ – or to make thicker cloths/carpets such as doublecloth (see below).

**Lampas** This term is used by CIETA to encompass all figured compound weaves that have a supplementary patterning weft that is bound down by a secondary binding warp. Otherwise there have been many meanings assigned to this term, including Indian chintzes, drawloom figured fabrics with metal threads, and, in the later nineteenth century, a Jacquard-woven silk with large patterns either imported from China or Persia, or made in Lyon. For our purposes the CIETA meaning is useful to denote a level of complexity without assigning a specific name to the cloth

**Brocade** There is no such thing as handwoven brocade, in that this is a technique whereby additional coloured wefts are added with a small bobbin only where needed in the figuring. It can be removed (‘drizzled’ if composed of metal threads) and the ground fabric remains whole. The reverse of the fabric clearly shows the isolated areas of supplementary brocading. The correct nomenclature should be ‘brocaded damask’ ‘brocaded satin’, etc.



**Brocatelle** Said to have been developed as an imitation of stamped leather, this cloth has a repoussé-like surface which, like damask, is usually composed of contrasting satin and matt weaves. The characteristic bulk is caused by the use of two densely set warps (typically silk) that when bound down by linen wefts cannot lie in the same plane and therefore rise one above the other. Brocatelle was introduced to Norwich in *circa* 1590 by Walloons from the Dutch Republic. By the eighteenth century, if not earlier, variants were produced with any fibre. A furnishing fabric, in Spitalfields it remained a silk and linen cloth.



**Damask** This cloth is not a compound weave, but instead is figured through the use of contrasting smooth and matt surfaces, which exchange on the reverse. The smooth areas are generally – but not always (as shown below) – regarded as the background for the pattern and woven in satin.



**Doublecloth** As its name implies, a doublecloth is formed from two warps and two wefts that, in principle, can independently form a fabric. The two cloths are bound together as weaving progresses by the exchange of threads from the surface fabric with threads from the under fabric. 'Pockets' of single cloth may occur, and in many doublecloths the finished cloth is reversible. However, variations include doublecloths bound together with an additional warp or weft and those with differing patterns on front and back, as well as treble cloth, which outside Britain is called 'triple cloth'. The reversible type when made in Wales is called **Welsh tapestry**'.

**Imberline** A damask-type figured fabric developed in France during the eighteenth century, this cloth has warp-ways stripes that are often shaded from dark to light (**ombré**).



**Liseré** Derived from the French for selvedge, this cloth is figured via a supplementary multi-coloured warp that floats on the back. Liseres often incorporate brocading.



**Tapestry** In power-woven cloths, this term denotes weft-intensive cloths that resemble tapestry in the complexity of the pattern.



**Tissue** This figured cloth has two distinguishing features: a second warp to act as a twill binder and three or more coloured wefts interwoven from selvedge to selvedge, and sometimes including metal threads. The distinctive 'banding' of each different colour is apparent on the reverse. In Macclesfield this process is referred to as **chintzing**.



## 7. Further Reading

### Principle Sources

FM = Florence Montgomery, *Textiles in America 1650-1870* (W W Norton & Company: 2014). Despite its title, the dictionary that forms more than half of this book is based on original documents, commercial records and pattern books containing original swatches, the majority of them European and with a particular emphasis on British goods.

*Fairchild's Dictionary of Textiles*, the standard reference book, has been continuously updated since its first publication in 1915. That first edition is available online at <https://archive.org/details/dictionaryoftext00harmrich> (sourced 24 February 2018).

### Other Sources

Anna Benson and Neil Warburton, *Looms and Weaving* (Shire album 154). Written by professional power loom weavers, this little volume has a brief historical introduction but places the focus on English looms, both hand- and power-driven, from c.1700 to the 1990s.

CIETA (Centre International d'Étude des Textiles Anciens), *Vocabulary of Technical Terms - English* (CIETA: 1964).

Clive Edwards, *Encyclopedia of Furnishing Textiles, Floorcoverings and Home Furnishing Practices 1200-1950* (Lund Humphries: 2007). Although focused on furnishings, this volume is also useful for the many cloths found in dress as well; in addition, it has excellent citations of original references and a comprehensive bibliography.

Eric Kerridge, *Textile Manufactures in Early Modern England* (Manchester University Press: 1988). This volume is worth consulting for the many 'New Draperies', or cloths that were introduced into Britain by the 16<sup>th</sup> and 17<sup>th</sup> century waves of immigrants.

James R. Planché, *Cyclopaedia of Costume* (Chatto and Windus: 1876), reprinted as *An Illustrated Dictionary of Historic Costume: From the First Century B.C. to c.1760* (Dover Publications 2003, later edition Courier Corporation 2013). Like the Kerridge volume, a useful reference in relation to cloths introduced prior to 1760 but continuing in production afterwards; additionally useful for its focus on textiles used in clothing.

Natalie Rothstein, *Silk Designs of the Eighteenth Century* (Thames & Hudson: 1990). Valuable both for the comprehensive illustration of patterns from the early 18<sup>th</sup> century into the early 19<sup>th</sup> century, as well as a glossary of terms.

Mary Schoeser, *World Textiles: A concise history* (Thames & Hudson: 2003). Of particular use is Chapter 8, 'The Importance of Cotton and Linen 1500-1950'.

Lucy Trench (ed.), *Materials and Techniques in the Decorative Arts: An illustrated dictionary* (John Murray: 2000). A useful general dictionary written by conservators, with the textile entries provided by Mary Schoeser and informing this document.

Worshipful Company of Weavers, *Glossary* at <http://weavers.org.uk/glossary> (sourced 21 February 2018).

## 8. Places to Visit

### **Working Weaving Museum & Heritage Centre Mills to Visit – UK**

**Paradise Mill**, Park Lane, Macclesfield, Cheshire SK11 6TJ

<https://macclesfieldmuseums.co.uk/venues/paradise-mill>

**Quarry Bank Mill**, National Trust, Styal, Wilmslow, Cheshire SK9 4LA

<https://www.nationaltrust.org.uk/quarry-bank>

**Helmshore Mills Textile Museum**, Holcombe Road, Helmshore, Rossendale, Lancashire BB4 4NP (currently finding a new operator Spring 2018)

<http://www.lancashire.gov.uk/leisure-and-culture/museums.aspx>

**Sir Richard Arkwright's Masson Mills**, Derby Road, Matlock Bath, Derbyshire DE4 3PY

<https://www.massonmills.co.uk>

**Whitchurch Silk Mill**, 28 Winchester Street, Whitchurch, Hampshire RG28 7AL

<http://whitchurchsilkmill.org.uk/mill/index.php>

**Paisley Museum**, High Street, Paisley Scotland PA1 2BA

<https://www.renfrewshireleisure.com/paisleymuseum/>

**Museum of Science of Industry**, Liverpool Road, Manchester M3 4FP

<https://www.msimanchester.org.uk/whats-on/textiles-gallery>

**Coldharbour Mill Museum**, Coldharbour, Uffculme, Cullompton, Devon EX15 3EE

<https://www.coldharbourmill.org.uk>

**Fairfield Mill**, Garsdale Road, Sedbergh, Cumbria LA10 5LW

<http://www.farfieldmill.org>

### **Working Weaving Mills to Visit – UK**

**Curlew Weavers**, Troed-yr-Aur Old Rectory, Rhydlewis, Newcastle Emlyn, Ceredigion, South Wales

<http://www.westwales.co.uk/curlew.htm>

**Rock Mill**, Capel Dewl, Llandysul, Ceredigion, South Wales SA44 4PH

<http://www.rockmillwales.co.uk>

**Melin Teifi**, Drefach, Felindre, Landysul, Carm, Wales SA44 5UP

<http://www.melinteifi.com>

**Melin Tregwynt**, Tregwynt Mill, Castlemorris, Haverfordwest, Wales SA62 5UX

<https://melintregwynt.co.uk>

**Ardalanish Farm & Isle of Mull Weavers**, Bunessan, Isle of Mull PA67 6DRT

<http://ardalanish.com>

**Knockando Woolmill**, Knockando, Aberlour, Moray AB38 7RP

<https://www.kwc.co.uk/pages/tours>

**Solva Woollen Mill**, Middle Mill, Solva, Haverfordwest, Pembrokeshire, Wales SA62 6XD

<http://www.solvawoollenmill.co.uk>

**Moon**, Netherfield Mills, Guiseley, Leeds, West Yorkshire LS20 9PD (group visits only)

<https://www.moons.co.uk>

## **Working Weaving Museums & Mills – Europe**

**Textiel Museum /Textiel Lab**, Goirkestraat 96, 5046 GN Tilburg, The Netherlands

<http://www.textielmuseum.nl/en/>

**Guiditta Brozetti**, Via Tiverio Berardi, 5/6 - 06123 Perugia Italy

<http://www.brozetti.com/en/>

**La Manufacture Roubaix**, 29 Avenue Julien Lagache, 59100 Roubaix, France

<http://lamanufacture-roubaix.com/fr/>

**Las Hilanderas**, Calle Manuel Taño, 4 El Paso, Isla de la Plama, Canarias

<http://lashilanderaselpaso.com/en/>

## **9. Picture Credits**

**All pictures courtesy and copyright of the School of Textiles accept the following:**

Decorative Arts Program of The American Federation of Arts, *Threads of History* (1965), pp.6, 7, 8, 9, 13, 15 TL

[XTextile.com](http://XTextile.com), p.10

Sara J. Kadolph, *Textiles*, (2007), pp.13, 29 T

School of Textiles, pp.15 TR, 15 B, 17, 18, 20, 21, 22, 24 R, 25, 26, 27 T, 29 B, 30 R, 32, 33, 34 B, 35, 36, 37 B, 39

Marianne Straub, *Hand Weaving and Cloth Design* (Pelham Books Ltd: 1977), photo Philip Sayer, p.19

Richard Humphries Weaving, p.23

Sue Kerry (private collection), pp.24 L, 27 B, 30 L, 31, 34 T, 38 T

Watts of Westminster, pp.37 T, 38 B